



## Nozomi 18000+ LED

Single-pass Printer for Point of Sale and Display Graphics Producers

Satisfy your need for speed  
in a single pass



# The first single-pass digital printer **designed and built** for the sign and display graphics market

Turnaround times are going down. Customer demand for versioning and variable jobs are going up. And for ultra-high-volume producers, there's a need for more speed.

No problem. The EFI™ Nozomi 18000+ LED is the single best printer to accelerate your business with the ability to run an impressive variety of substrates along with enhanced priming and print varnish capabilities.

Put it all together and the Nozomi 18000+ LED turbo-charges your throughput with super-high speed and ultra-high quality. All with just in time, on demand, every board is different print capability – and so much more – all in a single pass.





## Capabilities to accelerate your business

The Nozomi 18000+ LED digital press will reduce your cost-per-square printed by eliminating the make-ready costs associated with analogue (litho or screenprint). You will also add more burst capacity for a faster time-to-market and more opportunities to accommodate customer requests for versioning, variable data jobs, and last-minute changes. And by consolidating production onto a single super-high-speed platform, you'll reduce your footprint and labour resources.

# Turbo-charge your competitive edge

---



## Impressive substrate and application range

- Compatible with a wide range of materials with its all-LED-cure, drop-on-demand inkjet technology
  - Handles boards/sheets up to 12 mm thick or as thin as 0.3 mm with optional fully automatic feeding and stacking
  - Print to corrugated plastics and other adhesion-challenged materials with the UV primer
  - Print to reflective or coloured surfaces with optional pre-white
  - Add weatherability and UV protection to outdoor applications with the optional post UV coater
- 



## Super-high-speed production

- Productivity of 1,000+ 1.2 m x 2.4 m sheets per hour
  - 1.8-metre-wide, vacuum-integrated transport, up to 65 m/min
  - All the efficiencies needed to handle burst capacity for print runs from one to several thousand or more:
    - Pallet-to-pallet material automation
    - Automatic registration
    - Continuous inks with fully recirculating ink delivery system
    - Automatic nozzle plate cleaning
    - Intuitive user interface with dual touchscreens
    - Sheet thickness laser detector
    - Artificial vision system for colour uniformity, defect, and nozzle out detection
- 



## Ultra-high quality

- CMYK, plus optional White, Orange, and Violet
  - Optional Orange and Violet expand gamut to achieve 95+% of Pantone® library
  - Single-pass ink pile reduces ink cost 20-50% compared to shuttle-based
  - Full-width artificial vision quality inspection
  - UV-cured primer promotes consistent drop placement on all materials
  - Best-in-class Fiery® colour management suite with API connectivity to EFI IQ™ and eProductivity Software
-

And rev up your creative engine



# The single best super high speed LED printer for point of sale and display graphics producers

**INSPECTION AND CLEANING**  
Assures every board/sheet is ready to print

**REGISTRATION**  
High-speed registration table with optimised warp control

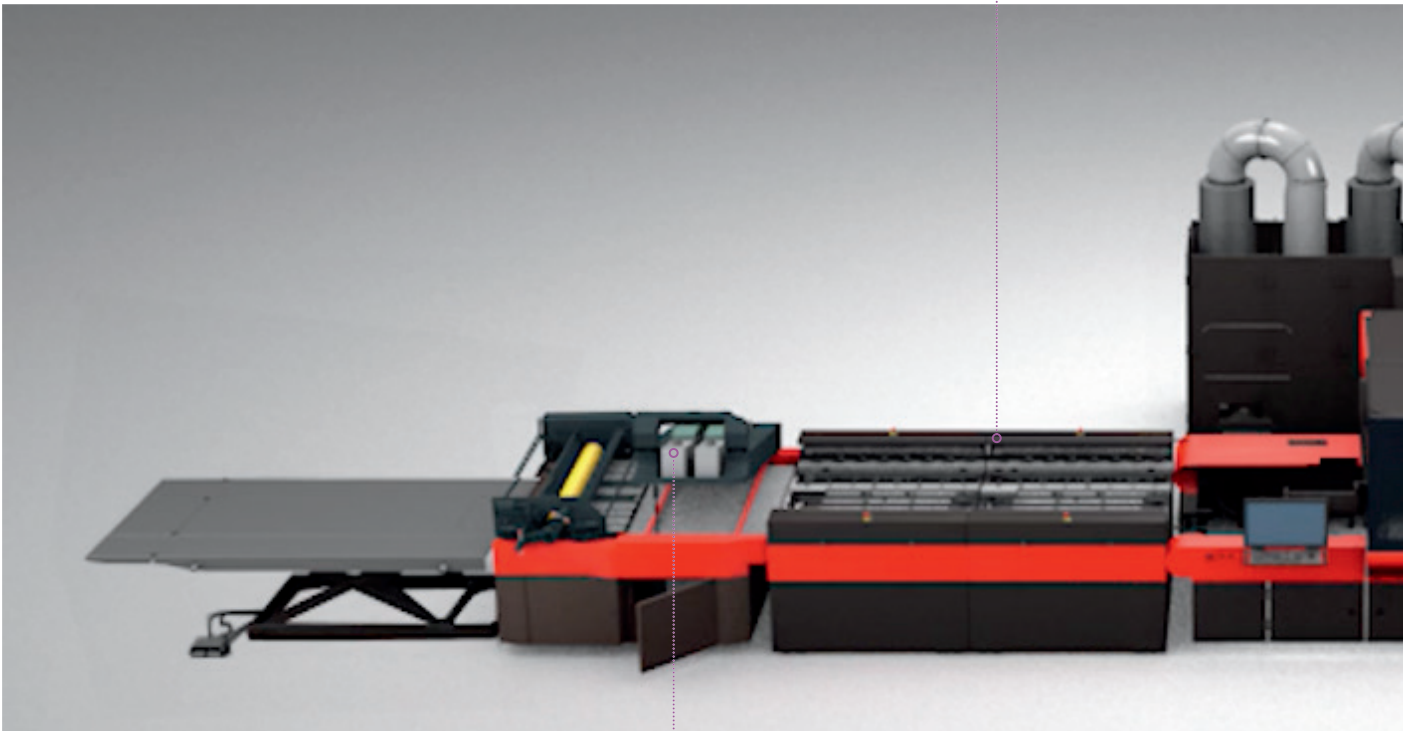

**PRIMER**

- UV coating for the widest range of substrates, including plastics, paper, and synthetics
- Exclusive air knife separator to keep materials moving

**INK CONFIGURATIONS**

BASE **C M Y K**

OPTIONAL **C M Y K + W**

**C M Y K + O V**

**C M Y K + O V + W**

## STACKING

Fully-automated material stacking

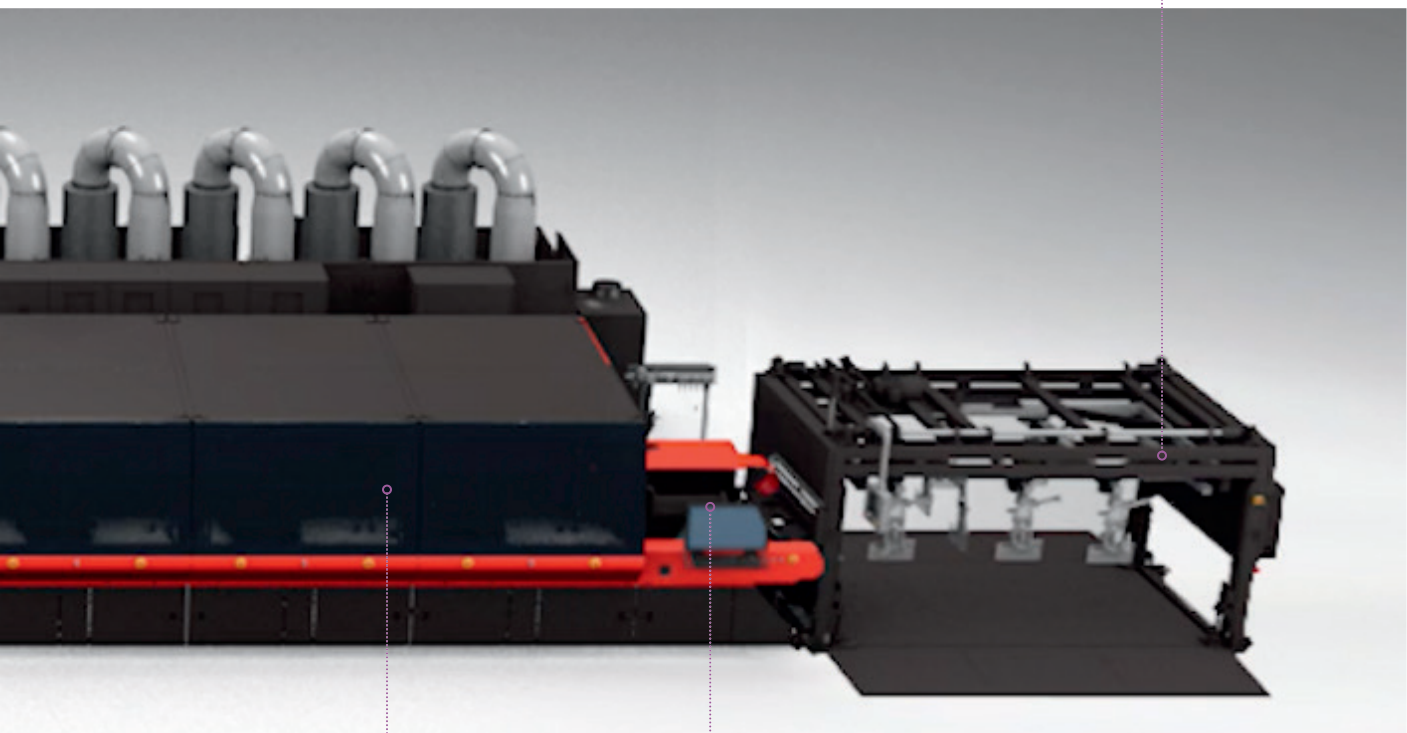

## PRINTER

- Single-pass, LED digital inkjet printer
- 7 industrial, fixed-array print bars
- Print resolutions: 360 dpi native; 720 dpi effective
- Four greyscale levels
- Optimised vacuum transport
- Ink system with recirculation, pressure and temperature control
- Automatic nozzle plate cleaning
- EFI Fiery Z-1000 digital front end

## ONBOARD QUALITY AGENT

Artificial vision system for colour adjustments and nozzle out detection

# Ultra-high-quality printing with Genuine EFI Inks

Our Genuine EFI Nozomi 18000+ LED Series inks have been custom formulated and exhaustively tested and optimised for the Nozomi 18000+ LED printer. Both the system and inks were developed in unison to assure you get great extended colour gamut, durability, reliability, consistency, and predictable running costs. Add our extensive colour range and best-in-class Fiery colour management suite, and you get all the quality and performance you'd expect from Genuine EFI Inks – so you always print with flying colours.





# Fiery technology – the **world leader** in digital front end innovation



EFI Fiery digital front ends (DFEs) are the industry standard and the most popular choice across multiple print environments. To succeed in today's highly competitive market, it is critical to have a DFE with integrated workflow and colour management to achieve higher operational efficiency and output quality. The Fiery NZ-1000 DFE provides outstanding image and colour quality with features to make your print results truly exceptional.

## Fiery technology delivers:

- Advanced colour management and extensive toolset for late-stage image editing
- Exceptional print and colour quality for complex, graphically rich content
- Stunning out-of-the-box colour with the smoothest colour blends, maximum shadow detail, and superb image definition
- Accurate reproduction of brand colours plus colour matching for consistent print results
- Intelligent automation that can analyse print jobs and dynamically choose the optimal print settings, reducing setup time
- Efficient job management with easy handling of short runs and versioned or variable data printing jobs
- Full visibility into your production with accurate ink estimates and reporting of the actual ink used in print
- Advanced bladed hardware architecture with the processing power to ensure the highest throughput

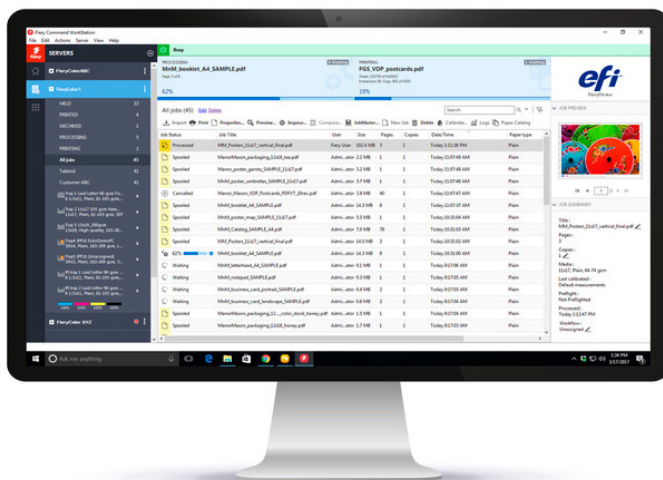

*Centralise print production control with Fiery Command WorkStation's intuitive job management interface*

# Value-added training and services working for you

We're there with you every step of the way – during installation, the ramp-up process, and during regular and intensive use – with the only purpose to ensure that you get the most out of your EFI Nozomi 18000+ LED single-pass printing investment.



## Ramp-up program

This 12-week program is designed to accelerate the learning curve and increase operator confidence with three weeks of hands-on operator and maintenance training plus nine weeks of onsite mentoring as you reach steady production.

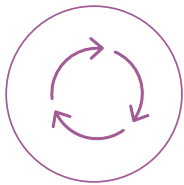

## Three keys of extended follow-up

With a focused goal of total machine stability, our extended follow-up is focused on three key areas: production monitoring, training, and maintenance. A senior field service engineer (FSE) works with you onsite for three months, and you're fully supported 24/7 by our remote support team.

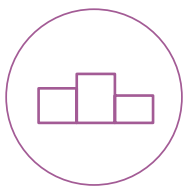

## Maintenance service

We offer three maintenance agreements levels – Bronze, Silver, Gold – based on production volumes for you to choose from to maintain optimal print quality, machine stability and reinforce technical training. The maintenance programmes include routine procedures and best practices to ensure optimum condition of all components and to avoid unforeseen downtime.



## Smart Support

Remote training and support enhanced with augmented reality for real-time, see-what-I-see communication and faster time to resolution.

# Add **intelligence** to your print business with EFI IQ

Unlock the value of your production data by connecting your printers to EFI IQ. Use the EFI IQ suite of cloud applications to make data-driven decisions so you can improve ROI, minimise cost, maximise profit, and boost revenue.

EFI IQ lets you connect your people, processes, and print devices, so you can make better data-driven decisions. Use the EFI IQ applications to:

- Visualise key production data and the current status of your printers in near real time
- Capture and transform print production data into actionable analytics to drive business improvement
- Stay connected to your print production systems, view print devices and monitor job data anytime, anywhere from your iOS and Android devices
- Receive alerts about production-blocking events, and automate the distribution of reports to ensure that you never miss any production issue

Build a stronger, more profitable business with your production data using EFI IQ applications.



## TECHNICAL DATA

Printing	
Technology	EFI single-pass, drop-on-demand digital inkjet
Maximum printing area	1800 mm wide x 3200 mm long
Resolution	360-720 dpi with 4 greyscale levels
Number of colours	Up to 7 colours with optional White, Orange, Violet:
Ink type	Genuine EFI UV LED inks
Primer	Enhanced primer included Optional over print varnish application
Digital front end	EFI Fiery NZ-1000 “blade” continuous feed system
Productivity (1.2 x 2.4 m boards)	
Single line printing	65 linear m/min
Manual feed	600+ boards/hour *
Full pallet-to-pallet automation	1,000+ boards/hour
Media handling	
Maximum print width	1800 mm
Media thickness	From 0.30 mm (12 points) to 12.7 mm (0.011-1.38 in)
Stacking	Not available for substrates less than 0.8 mm thick
Automation	¾ automation or pallet to pallet
Environmental considerations	
Footprint (LxWxH): Scissor lift table, UV primer, registration module, configurable printer, stacker	36.5 m x 11.28 m x 3 m
Temperature inside cabin	23 - 28 °C
Relative humidity	20-80% non-condensing
Electrical	350A at 380V or 280A at 480V supply
Air	Clean and dry air, 6.5 bar

\* Manual throughput dependent on operator loading time

## Let's be brilliant. Together.

We understand you want breakthrough technologies to lead you through your digital journey. That's why we're passionate about driving your business growth with a scalable portfolio of products, solutions, services, support, and world-class partnerships for the manufacturing of signage, packaging, textiles, ceramic tiles, building materials, commercial print, and personalised documents with a wide range of printers, inks, digital front ends, and workflow software. Our unwavering commitment is to increase your profits, cut costs, improve productivity, and optimise efficiency — job after job, year after year. We're obsessed with your success. And we definitely believe we have the right people, technology and experience to help your business achieve its goals. Visit [www.efi.com](http://www.efi.com) or call 0808 101 3484 (UK only) for more information.



Nothing herein should be construed as a warranty in addition to the express warranty statement provided with EFI products and services.

AutoCal, Best Eye, ColorGuard, ColorPASS, ColorRight, ColorWise, Command WorkStation, Cretachrom, Cretaprint, the Cretaprint logo, Cretaprinter, Cretaroller, Divisional Graphics, Distancing Graphics, DocBuilder, Dynamic Wedge, EDOX, EFI, the EFI logo, Electronics For Imaging, FabriVu, Fast-4, FASTRIP, FASTDRIVE, Fiery, the Fiery logo, Fiery Compose, Fiery Driven, the Fiery Driven logo, Fiery Edge, Fiery Essential, Fiery HyperRIP, Fiery Impose, Fiery Impress, Fiery ImageViewer, Fiery Intensify, Fiery JobExpert, Fiery JobFlow, Fiery JobMaster, Fiery Navigator, Fiery Prep-it, Fiery Prints, the Fiery Prints logo, Fiery TrueBrand, FreeForm, Inkintensity, Inkware, IQ, MicroPress, OneFlow, PressVu, PrintMe, the PrintMe logo, Prograph, ProGraphics, RIPChips, RIP-While-Print, SafeGuard Graphics, Spot-On, Spot Pro, UltraDrop, UltraPress, UltraTex, UltraVu, UV Series 50, VUTEK, the VUTEK logo, and WebTools are trademarks or registered trademarks of Electronics For Imaging, Inc. and/or its wholly owned subsidiaries in the U.S. and/or certain other countries.

All other terms and product names may be trademarks or registered trademarks of their respective owners and are hereby acknowledged.

© 2022 ELECTRONICS FOR IMAGING, INC. ALL RIGHTS RESERVED. | [WWW.EFI.COM](http://WWW.EFI.COM)

AC\_59\_08\_22\_UK