



Reggiani EXTRA

Digital Printer for
Direct Printing on Fabric and Paper

EXTRA colours.
EXTRA speed.
EXTRAordinary results.

EXTRA colours. EXTRA speed. EXTRAordinary results.

The EFI™ Reggiani EXTRA digital printer is where brilliant colours, exceptional printing quality and high productivity meet. With up to 12 different colours in a row, you can extend your colour gamut and depth, increase penetration, and enhance printing quality and uniformity without compromising on performance. Plus, thanks to the 48 new recirculation print heads and legacy EFI Reggiani continuous ink recirculation system, the EFI Reggiani EXTRA printer is also a champion for uptime and reliability, maximising the printer's availability for production print results.

At a glance

- Unparalleled versatility at high speeds
 - Up to 12 colours for superior printing uniformity and colour depth
 - 6+6 colours for higher productivity without compromising on colour intensity
 - Possibility to create your colour configuration with light, fluorescent and special colours, as well as special chemistries to enhance penetration and colour brightness
- Always ready to print with 48 new print heads with recirculation to the nozzle plate
- Proprietary continuous ink recirculation system to reduce maintenance at start up and during production
- Longitudinal belt movement control for superior printing accuracy
- Unparalleled design security thanks to the encrypted connection with Inèdit workflow for EFI Reggiani printers
- Powered by EFI Reggiani genuine inks
- Industry 4.0 friendly

APPLICATIONS	
Apparel and accessories	✓
Home textile	✓
Sportswear and footwear	✓
Outdoor	✓
INKS	
Reactive	✓
Disperse direct	✓
Acid	✓
Disperse sublimation	✓
Pigment	✓
SUBSTRATES	
Cotton	✓
Polyester	✓
Polyamide	✓
Silk	✓
Viscose	✓
Polyester and elastane	✓
Polyamide and elastane	✓
Blends	✓
Wool	✓
Sublimation paper	✓

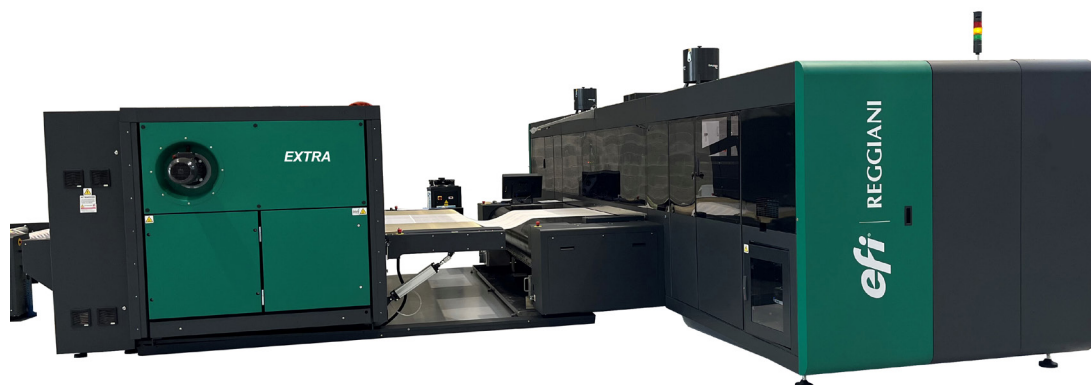

Print heads and ink system

- Up to 12 colours
- 48 recirculation print heads with 600 dpi native resolution
- Full variable drop size
- Printing resolution up to 600 x 2400 dpi
- Nozzles always ready to print, reducing maintenance needs and production stoppages
- Missing nozzles reduction to print difficult designs at faster speeds
- Enhanced auto-calibrating continuous ink recirculation system
- Ink management: in-line continuous degassing and filtering
- Print head crash protective system

Fabric handling

- EFI Reggiani exclusive dynaplast roll compensating step vs. continuous movement
- High-precision transportation belt
- Fabric print centering sensor on the carriage
- Live media check: your design will automatically be placed on the fabric
- Embedded magnetic system for adhesive application
- Possibility to use thermoplastic, resin and permanent adhesives
- EFI Reggiani original longitudinal belt movement control
- Belt washing with both continuous and stop-and-go capabilities with air blade included

Printing carriage

- Steel bridge with linear motor and magnetic encoders, reaching 2+ m/s speed
- Easy carriage access for smooth maintenance on all the print heads
- Ink temperature always under control for more accurate drop formation
- Integrated environmental sensor for constant humidity and temperature monitoring
- Ink tanks refill without stopping the printer

Electronics and software

- EFI Reggiani proprietary electronics and software
- Real-time image processing: no image pre-calculation
- Printing parameters and geometry change on the fly
- High uniformity printing modes
- Job editor: what you see is what you get at each and every moment
- Reporting and diagnostics available from GUI
- Possibility to monitor and export all printing and printer data to an external DB or ERP
- Components with double CE and UL/CSA certification, guaranteeing high-quality standards recognised worldwide
- Suitable for integration in Industry 4.0 projects

EFI REGGIANI EXTRA 1.5M					
RESOLUTION	PASS	STANDARD SPEED M/H	STANDARD SPEED SQM/H	FAST SPEED* M/H	FAST SPEED* SQM/H
600 x 300	1	560	840	670	1005
600 x 600	2	300	450	340	510
600 x 900	3	200	300	230	345
600 x 1200	4	150	225	170	255

EFI REGGIANI EXTRA 3M					
RESOLUTION	PASS	STANDARD SPEED M/H	STANDARD SPEED SQM/H	FAST SPEED* M/H	FAST SPEED* SQM/H
600 x 300	1	420	1260	530	1590
600 x 600	2	220	660	265	795
600 x 900	3	150	450	175	525
600 x 1200	4	110	330	130	390

* Powered by a selection of EFI Reggiani genuine inks. 6+6 colours configuration: double ink laydown at same speed.

Specifications

Printing width	180, 340 cm
Print heads	48
Printing resolution	Up to 600 x 2400 dpi
Fabric weight	From 30 to 450 gr/sqm
Fabric feed (Entry)	Small roll unwinder up to \varnothing 400 mm Big roll unwinder (A frame) up to \varnothing 1,600 mm Fold
Fabric take-up (Exit)	Fold Small roll winder up to \varnothing 400 mm Big roll winder (A frame) up to \varnothing 1,600 mm
Dryer	Industrial single- or double-section dryer Symmetric ventilation and high efficiency exhaust capacity Heating sources available: gas, electricity, oil and steam

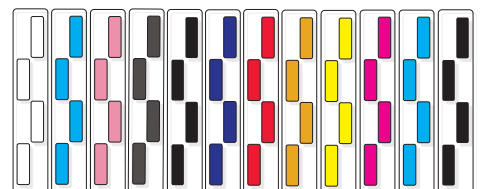
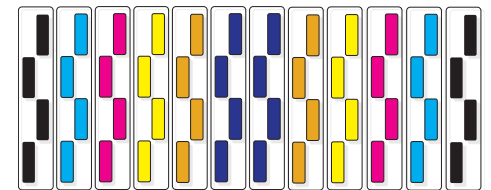
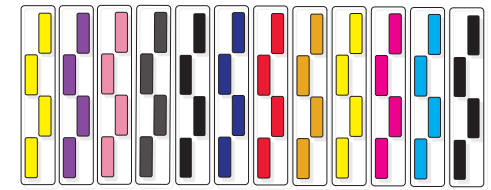

*Further colour configurations available

EFI Reggiani EXTRA: Regulatory model ReNOIR 180, ReNOIR 340
More options for sublimation paper configuration

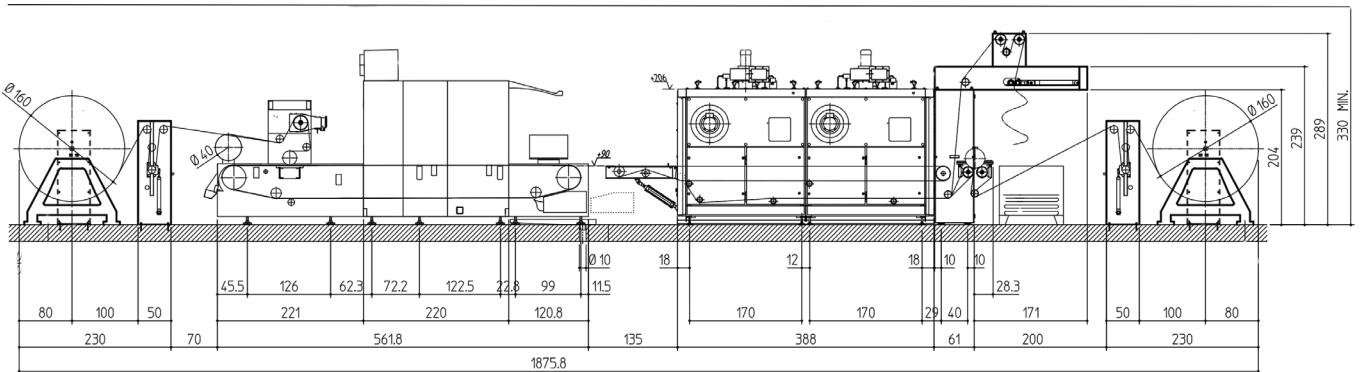

Let's be brilliant. Together.

We understand you want breakthrough technologies to lead you through your digital journey. That's why we're passionate about driving your business growth with a scalable portfolio of products, solutions, services, support, and world-class partnerships for the manufacturing of signage, packaging, textiles, ceramic tiles, and building materials with a wide range of printers and inks. Our unwavering commitment is to increase your profits, cut costs, improve productivity, and optimise efficiency — job after job, year after year. We're obsessed with your success. And we definitely believe we have the right people, technology and experience to help your business achieve its goals. Visit www.efi.com/reggiani or call +39 035 3844511 for more information.



Nothing herein should be construed as a warranty in addition to the express warranty statement provided with EFI products and services.

BDR, Cretachrom, Cretaprint, the Cretaprint logo, Cretaprinter, Cretaroller, Divisional Graphics, Distancing Graphics, EFI, the EFI logo, Electronics For Imaging, FabriVu, Fast-4, Inêdit, Inkintensity, Inkware, neoCatalog, neoStampa, neoTextil, PressVu, ProGraphics, Rialco, Riaplas, SDC, SafeGuard Graphics, UltraDrop, UltraPress, UltraVu, UV Series 50, VUTEK, and the VUTEK logo are trademarks or registered trademarks of Electronics For Imaging, Inc. and/or its wholly owned subsidiaries in the U.S. and/or certain other countries.

All other terms and product names may be trademarks or registered trademarks of their respective owners and are hereby acknowledged.

© 2024 ELECTRONICS FOR IMAGING, INC. ALL RIGHTS RESERVED. | WWW.EFI.COM

RE_o3_o8_24_UK